

OPERATION MANUAL

Industrial humidity/temperature sensor with analog output signal 4...20 mA - 0555 1506-01

Description



Performance characteristics

- Humidity measurement linearized and temperature compensated
- High long-term stability, innovative technology
- Probe housing stainless steel 1.4571
- High-quality aluminum diecast
- Sensor head with sintered filter
- Signalausgang (Temp. + Feuchte) 4...20 mA

Application areas

- Industrial measurement and control technology
- Measurement of low humidity
- Drying technologie
- Additive manufacturing processes (3D printing)

Operational area

In industrial applications, particularly high demands are placed on precision and long-term stability of measuring systems, even under extreme operating conditions.

The B+B humidity sensors meet these requirements to a particularly high degree thanks to the latest sensor technology and innovative design. The measuring probe made of high-quality stainless steel is made pressure-resistant on the probe head via a Teflon feed-through and the electronics are provided with a waterproof M12 connector. The thermally insulated evaluation electronics, which are separated from the sensor, prevent self-heating and to achieve a significantly higher level of precision in the humidity measurement. The relative humidity is measured with a capacitive polymer sensor element, which guarantees the highest precision and long-term stability with excellent chemical resistance. To ensure high measurement accuracy in the entire temperature range, the humidity measurement is linearized and temperature compensated. The humidity values are output as a standardized, analog current signal. The humidity values are output as a standardized, analog current signal. Power is supplied with 12...24 V DC. The sensor is protected against overvoltage and transients by an integrated protective circuit.

Technical data

Humidity measurement

Measuring range 0...100 % RH, not condensing

Accuracy $\pm 0,5$ % RH (0...5 % RH)
 $\pm 1,0$ % RH (5...10 % RH)
 $\pm 1,5$ % RH (10...20 % RH)
 ± 3 % RH (20...30 % RH)

Response time t_{90} ca 20 sec.

Output scaling 4 areas, DIP switches

Temperature measuring

Measuring range -20...+80 °C

Accuracy $\pm 0,5$ °C (-20...+60 °C)

Output scaling 2 areas, DIP switches

General

CE conformity 2014/30/EU

EMV Störaussendung EN 61000-6-3:2011

EMC emissions EN 61000-6-2:2007

Dimensions probe Tube $\varnothing 12$ mm x 128,5 mm incl. filter

Housing probe Stainless steel 1.4571

Protective filter PTFE sintered filter 12 x 32 mm, 15 μ m

Housing Aluminum diecast

Connection M12 industrial connector (m), 4-pin

Cable PVC cable 1500 mm

Operating voltage 16...24 V DC

Overvoltage protection Varistor and RC filter

Pressure resistance ± 1 bar

OPERATION MANUAL

Industrial humidity/temperature sensor with analog output signal 4...20 mA - 0555 1506-01

Drilling template

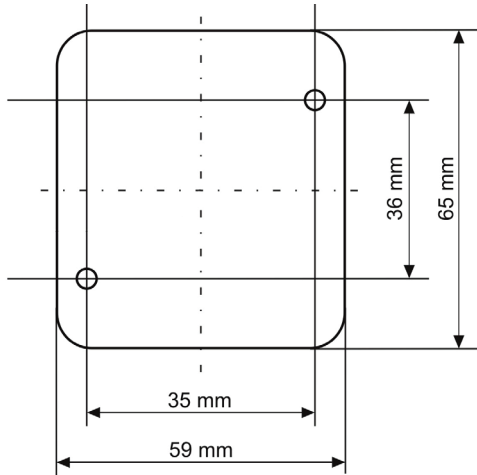

Output scaling, DIP switch

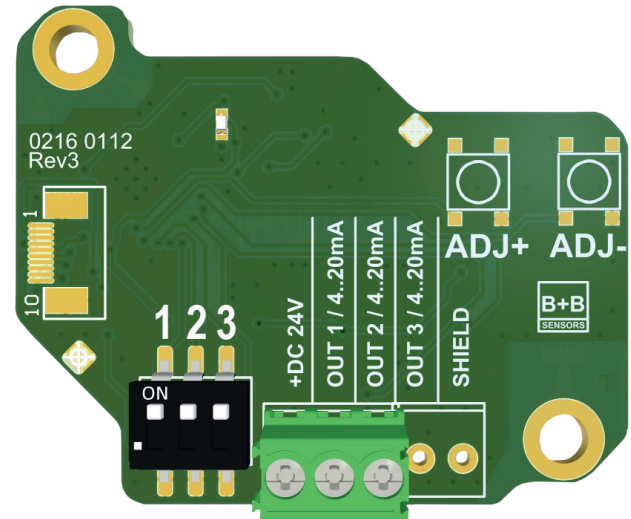

Pin assignments

Humidity measurement 4...20 mA and temperature measurement 4...20 mA, a common M12 connector

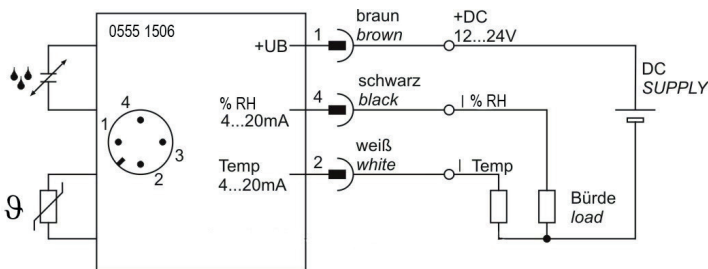

Pin	Function	Description
1 br	+UB	Positive operating voltage
2 ws	Temp 4...20 mA	Temperature signal 4...20 mA
3 bl	(-UB)	Not used
4 sw	% RH 4...20 mA	Humidity signal 4...20 mA

Temperature and humidity each two-wire connection, supply voltage + UB for both transducers together.

Dimensional drawing

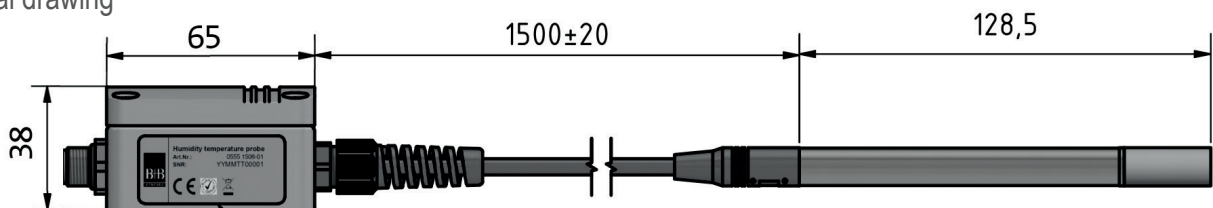

Output humidity

DIP switch		Output % RH
2	1	
OFF	OFF	0-100
OFF	ON	0-50
ON	OFF	0-25
ON	ON	0-10

Output temperature

DIP switch	Output °C
3	
OFF	-40-60
ON	0-50

Attention

Extreme mechanical and improper use must be avoided at all costs. The product cannot be used in potentially explosive areas or in medical technology applications.